

3/8" MP Male
9/16"-18UN Thread
per MASTER_6MM rev1

1/4" BSP Male
1/4"-19BSP Thread
per MASTER_4BM rev1

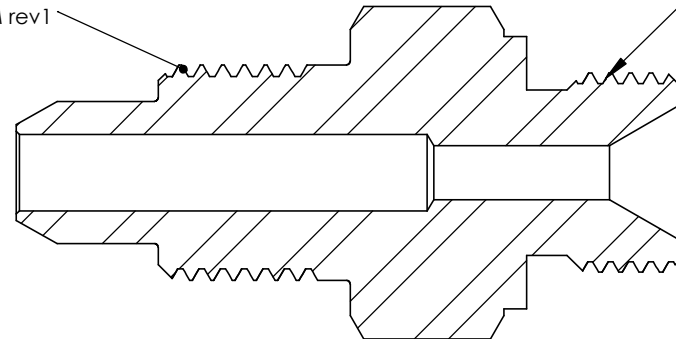

SECTION A-A

UNLESS OTHERWISE SPECIFIED:

- 1) DIMENSIONS ARE IN INCHES
- 2) TOLERANCES:
FRACTIONAL $\pm 1/64"$
ANGULAR: MACH $\pm 2^\circ$
ONE PLACE DECIMAL $\pm .020$
TWO PLACE DECIMAL $\pm .010$
THREE PLACE DECIMAL $\pm .005$
- 3) THREADS UNIFIED CLASS
2A - 2B
- 4) SURFACE FINISH 63 μ in Ra
- 5) CHAMFER THREADS:
MALE - 30° TO ROOT
FEMALE - 45° TO ROOT

	NAME	DATE
DRAWN	MH	6/8/2017
CHECKED	KH	6/8/2017
DATE STARTED IN PRODUCTION:		
6/8/2017		

**ULTRA PRESSURE COMPONENTS
HOUSTON, TX**

TITLE:
3/8" MP MALE X 1/4" BSP MALE

SIZE A	DWG. NO. 5404-6M4B	REV 0
------------------	------------------------------	-----------------

SCALE: 2:1 WEIGHT: 0.11 SHEET 1 OF 1



REVISION NOTES AND DATES

PROPRIETARY AND CONFIDENTIAL

THE INFORMATION CONTAINED IN THIS DRAWING IS THE SOLE PROPERTY OF ULTRA PRESSURE COMPONENTS. ANY REPRODUCTION IN PART OR AS A WHOLE WITHOUT THE WRITTEN PERMISSION OF ULTRA PRESSURE COMPONENTS IS PROHIBITED.