

3/8" HP Female
3/4"-16UNF Thread

3/8" MP Male
9/16"-18UN Thread

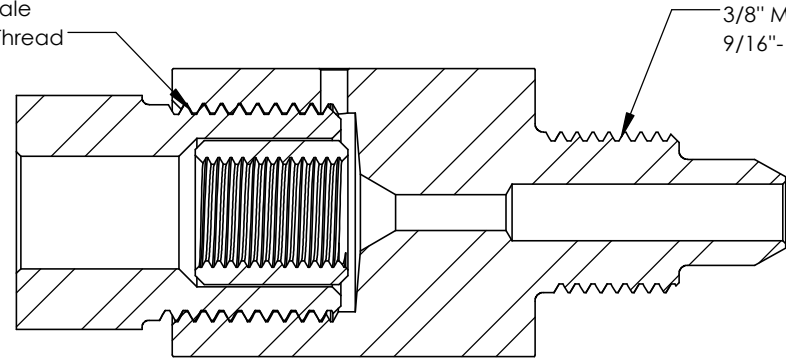

SECTION B-B

REVISION NOTES AND DATES

UNLESS OTHERWISE SPECIFIED:

ALL DIMENSIONS ARE IN INCHES
TOLERANCES AS FOLLOWS:
1 PLACE DECIMAL (.0): ±.030
2 PLACE DECIMAL (.00): ±.020
3 PLACE DECIMAL (.000): ±.010
ANGLES: ±2°

SURFACE FINISH: 63RMS
BREAK ALL EDGES: .010-.015
FILLETS & ROUNDINGS: R.015 - 0.30

THREADS UNIFIED CLASS 2A - 2B
CHAMFER THREADS 45° TO ROOT
30° CHAMFER IS OPTIONAL
FOR MALE THREADS ONLY

	NAME	DATE
DRAWN	BM	8/14/2020
CHECKED	KH	8/14/2020
DATE STARTED IN PRODUCTION:		
8/14/2020		



**ULTRA PRESSURE COMPONENTS
HOUSTON, TX**

TITLE:

3/8" HP Female x 3/8" MP Male
20,000 psi

SIZE	DWG. NO.	REV
A	5406-6H6M-CUST	1

SCALE: 1.5:1 WEIGHT: 0.38 SHEET 1 OF 1

PROPRIETARY AND CONFIDENTIAL

THE INFORMATION CONTAINED IN THIS DRAWING IS THE SOLE PROPERTY OF ULTRA PRESSURE COMPONENTS. ANY REPRODUCTION IN PART OR AS A WHOLE WITHOUT THE WRITTEN PERMISSION OF ULTRA PRESSURE COMPONENTS IS PROHIBITED.