

9/16" MP Male
13/16"-16UN Thread
per MASTER_9MM

9/16" MP Male
13/16"-16UN Thread
per MASTER_9MM

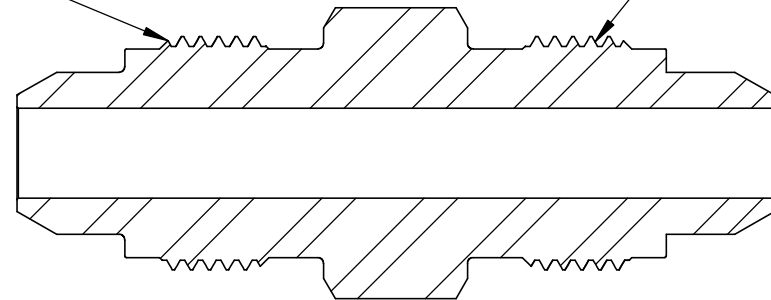

SECTION A-A

REVISION NOTES AND DATES

UNLESS OTHERWISE SPECIFIED:

- 1) DIMENSIONS ARE IN INCHES
- 2) TOLERANCES:
FRACTIONAL $\pm 1/64"$
ANGULAR: MACH $\pm 2^\circ$
ONE PLACE DECIMAL $\pm .020$
TWO PLACE DECIMAL $\pm .010$
THREE PLACE DECIMAL $\pm .005$
- 3) THREADS UNIFIED CLASS
2A - 2B
- 4) SURFACE FINISH 63 μ in Ra
- 5) CHAMFER THREADS:
MALE - 30° TO ROOT
FEMALE - 45° TO ROOT

	NAME	DATE
DRAWN	MH	5/26/2017
CHECKED	KH	5/26/2017
DATE STARTED IN PRODUCTION:		
5/26/2017		

**ULTRA PRESSURE COMPONENTS
HOUSTON, TX**

TITLE:

9/16" MP Male x 9/16" MP Male
20,000psi

SIZE A	DWG. NO. 5404-9M9M	REV 0
------------------	-----------------------	-----------------

SCALE: 1.5:1 WEIGHT: 0.26 SHEET 1 OF 1

PROPRIETARY AND CONFIDENTIAL
THE INFORMATION CONTAINED IN THIS DRAWING IS THE SOLE PROPERTY OF ULTRA PRESSURE COMPONENTS. ANY REPRODUCTION IN PART OR AS A WHOLE WITHOUT THE WRITTEN PERMISSION OF ULTRA PRESSURE COMPONENTS IS PROHIBITED.

